



**Alternators**  
**LSA 43.2 - 4 Pole**  
Electrical and mechanical data

### SPECIALY ADAPTED FOR APPLICATIONS

The LSA 43.2 alternator is designed to be suitable for typical generator applications, such as: backup, standard production, cogeneration, marine applications, rental, telecommunications, etc.

### COMPLIANT WITH INTERNATIONAL STANDARDS

The LSA 43.2 alternator conforms to the main international standards and regulations:

IEC 60034, NEMA MG 1.22, ISO 8528/3, CSA, UL 1446, UL 1004B on request, marine regulations, etc.

It can be incorporated into a CE marked generator.

The LSA 43.2 is designed, manufactured and marketed in an ISO 9001 environment.

### TOP OF THE RANGE ELECTRICAL PERFORMANCE

- Class H insulation.
- Standard 12-wire re-connectable winding, 2/3 pitch, type no. 6 .
- Voltage range: 220 V - 240 V and 380 V - 415 V (440 V) - 50 Hz / 208 V - 240 V and 380 V - 480 V - 60 Hz.
- High efficiency and motor starting capacity.
- Other voltages are possible with optional adapted windings:
  - 50 Hz: 440 V (no. 7), 500 V (no. 9), 600 V (no. 22 or 23), 690 V (no. 10 or 52)
  - 60 Hz: 380 V and 416 V (no. 8), 600 V (no. 9).
- Total harmonic content < 2%.
- R 791 interference suppression conforming to standard EN 55011 group 1 class B standard for European zone (CE marking).

### EXCITATION AND REGULATION SYSTEM SUITED TO THE APPLICATION

Excitation system				Regulation options				
Voltage regulator	SHUNT	AREP	PMG	T.I. Current transformer for paralleling	R 726 Mains paralleling	R 731 3-phase sensing	R 734 3-phase sensing on mains paralleling unbalanced	P Remote voltage potentiometer
R 250	Std	-	-	-	-	-	-	√
R 438	-	Std	Std	√	√	√	√	√
R 448	optional	-	-	√	√	√	√	√
D 510	-	optional	optional	√	included	included	NA	√

Voltage regulator accuracy +/- 0.5%. - √ : possible adaptation - NA : not possible.

### PROTECTION SYSTEM SUITED TO THE ENVIRONMENT

- The LSA 43. 2 is IP 23.
- Standard winding protection for clean environments with relative humidity ≤ 95 %, including indoor marine environments.

Options:

- Filters on air inlet and air outlet (IP 44).
- Winding protections for harsh environments and relative humidity greater than 95%.
- Space heaters.
- Thermal protection for windings and shields.

### REINFORCED MECHANICAL STRUCTURE USING FINITE ELEMENT MODELLING

- Compact and rigid assembly to better withstand generator vibrations.
- Steel frame.
- Cast iron flanges and shields.
- Twin-bearing and single-bearing versions designed to be suitable for engines on the market.
- Half-key balancing.
- Greased for life bearings.

### ACCESSIBLE TERMINAL BOX PROPORTIONED FOR OPTIONAL EQUIPMENT

- Easy access to the voltage regulator and to the connections.
- Possible clusion of accessories for paralleling, protection and measurement.
- 8 way terminal block for reconnecting voltage reconnection.

Option :

- D 510 digital AVR fitted in the terminal box.

## Common data

Insulation class	H	Excitation system	SHUNT	A R E P or PMG
Winding pitch	2/3 ( bob 6 )	A.V.R. model	R 250	R 438
Terminals	12	Voltage regulation (*)	± 0,5 %	± 0,5 %
Drip proof	IP 23	Sustained short-circuit current	-	300% (3 IN) : 10s
Altitude	≤ 1000 m	Total harmonic TGH / THC (**)	at no load < 2 % - on load < 2 %	
Overspeed	2250 min <sup>-1</sup>	Waveform : NEMA = TIF	< 50	
Air flow	0,27 m <sup>3</sup> /s (50Hz)/ 0,32 (60Hz)	Wave form : I.E.C. = THF	< 2 %	

(\*) Steady state duty. (\*\*) Total harmonic content line to line, at no load or full rated linear and balanced load.

## Ratings 50 Hz - 1500 R.P.M.

kVA / kW - Power factor = 0,8																					
Duty T°C	Continuous duty 40°C					Continuous duty 40°C					Stand-by / 40 °C			Stand-by / 27 °C							
Class / T° K	H / 125° K					F / 105° K					H / 150° K			H / 163° K							
Phase	3 ph.			1 ph.		3 ph.			1 ph.		3 ph.			1 ph.		3 ph.			1 ph.		
Y	380V	400V	415V	440V	ΔΔ	380V	400V	415V	440V	ΔΔ	380V	400V	415V	440V	ΔΔ	380V	400V	415V	440V	ΔΔ	
Δ	220V	230V	240V	230V		220V	230V	240V	230V		220V	230V	240V	230V		220V	230V	240V	230V		
YY	220V					220V					220V				220V						
43.2 S1	kVA	35	35	35	35	24	33	33	33	33	22	40	40	40	40	26	45	45	45	45	27
	kW	28	28	28	28	19	26	26	26	26	18	32	32	32	32	21	36	36	36	36	22
43.2 S15	kVA	40	40	40	40	28	36	36	36	36	26	44	44	44	44	30	47	47	47	47	31
	kW	32	32	32	32	22	29	29	29	29	21	35	35	35	35	24	38	38	38	38	25
43.2 S25	kVA	45	45	45	45	31	43	43	43	43	29	49	49	49	49	33	52	52	52	52	34
	kW	36	36	36	36	25	34	34	34	34	23	39	39	39	39	26	42	42	42	42	27
43.2 S35	kVA	50	53	52	47	33	45	48	47	42	30	53	56	55	50	35	55	58	57	53	36
	kW	40	42	42	38	26	36	38	38	34	24	42	45	44	40	28	44	46	45	42	29
43.2 M45	kVA	56	60	60	60	35	51	53	53	53	32	59	63	63	63	37	62	66	66	66	38
	kW	45	48	48	48	28	41	42	42	42	26	47	50	50	50	30	50	53	53	53	30
43.2 L65	kVA	67	70	69	68	41	61	62	63	62	38	71	74	73	73	43	74	77	76	75	45
	kW	53	56	55	55	33	49	50	50	50	30	57	59	58	58	34	59	62	61	60	36
43.2 L8	kVA	78	80	78	76	48	71	73	71	70	45	83	84	83	83	53	86	88	86	84	54
	kW	62	64	63	61	38	57	58	57	56	36	66	67	66	66	42	69	70	69	67	43

## Ratings 60 Hz - 1800 R.P.M.

kVA / kW - Power factor = 0,8																					
Duty T°C	Continuous duty 40°C					Continuous duty 40°C					Stand-by / 40 °C			Stand-by / 27 °C							
Class / T° K	H / 125° K					F / 105° K					H / 150° K			H / 163° K							
Phase	3 ph.			1 ph.		3 ph.			1 ph.		3 ph.			1 ph.		3 ph.			1 ph.		
Y	380V	416V	440V	480V	ΔΔ	380V	416V	440V	480V	ΔΔ	380V	416V	440V	480V	ΔΔ	380V	416V	440V	480V	ΔΔ	
Δ	220V	240V	240V			220V	240V	240V			220V	240V	240V			220V	240V	240V			
YY	208V					208V					208V				208V						
43.2 S1	kVA	44	44	44	44	28	40	40	40	40	25	50	50	50	50	29	56	56	56	56	30
	kW	35	35	35	35	22	32	32	32	32	20	40	40	40	40	23	45	45	45	45	24
43.2 S15	kVA	50	50	50	50	31	45	45	45	45	28	54	55	55	55	33	56	59	59	59	34
	kW	40	40	40	40	25	36	36	36	36	22	43	44	44	44	26	45	47	47	47	27
43.2 S25	kVA	51	54	56	56	35	47	50	50	50	32	54	58	59	59	37	56	60	62	62	38
	kW	41	43	45	45	28	38	40	40	40	26	43	46	47	47	30	45	48	50	50	30
43.2 S35	kVA	53	58	60	66	36	49	53	55	59	34	57	61	64	69	39	59	63	66	73	40
	kW	42	46	48	53	29	39	42	44	47	27	46	49	51	55	31	47	50	53	58	32
43.2 M45	kVA	57	62	64	71	39	53	57	59	64	36	62	66	69	75	42	64	68	71	78	43
	kW	46	50	51	57	31	42	46	47	51	29	50	53	55	60	34	51	54	57	62	34
43.2 L65	kVA	67	72	75	83	45	62	66	69	74	42	72	77	80	87	48	74	80	84	91	50
	kW	54	58	60	66	36	50	53	55	59	34	58	62	64	70	38	59	64	67	73	40
43.2 L8	kVA	80	85	88	95	53	73	78	81	87	49	86	91	95	102	57	88	95	99	107	59
	kW	64	68	70	76	42	58	62	65	70	39	69	73	76	82	46	70	76	79	86	47

## Efficiencies 50 Hz - P.F. : 1 / P.F. : 0,8

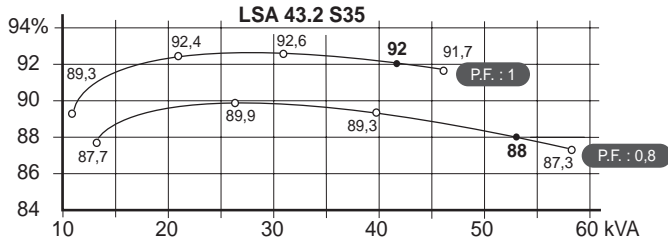
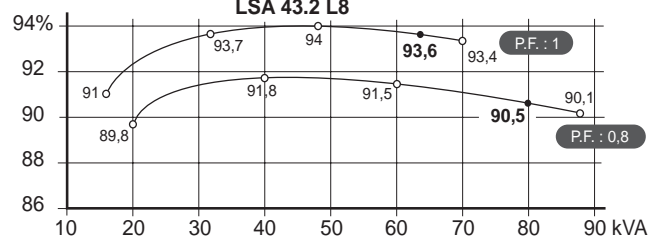
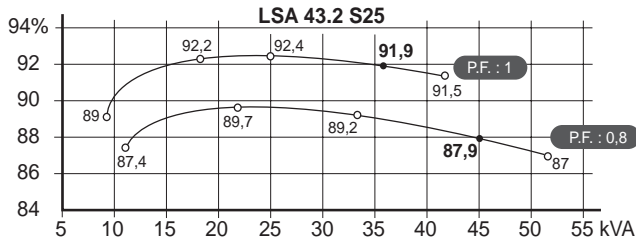
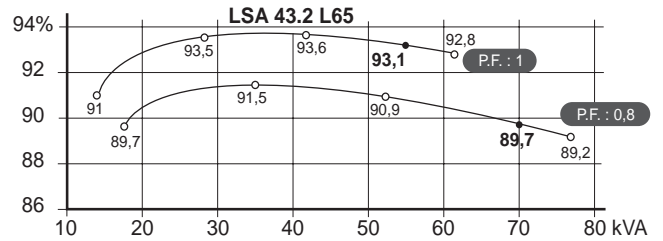
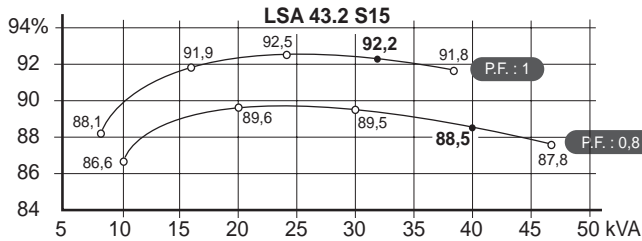
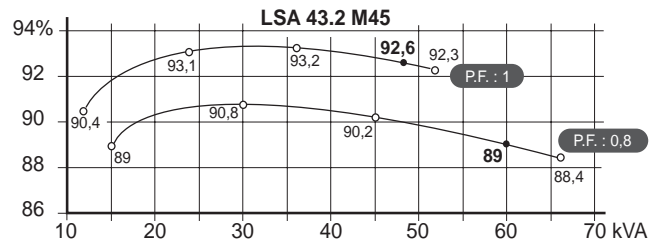
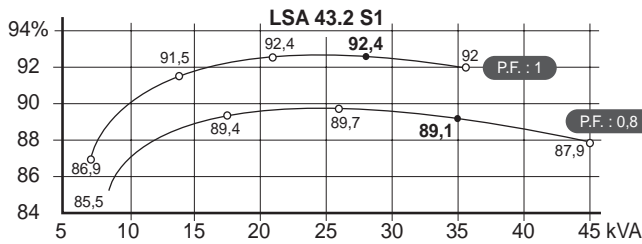

## Reactances (%) . Time constants (ms) - Class H / 400 V

	S1	S15	S25	S35	M45	L65	L8
<b>Kcc</b> Short-circuit ratio	0,54	0,48	0,42	0,43	0,39	0,37	0,41
<b>Xd</b> Direct axis synchro.reactance unsaturated	223	255	287	292	304	310	284
<b>Xq</b> Quadra. axis synchr.reactance unsaturated	134	153	172	175	182	186	170
<b>T'do</b> Open circuit time constant	1131	1131	1131	1177	1270	1354	1431
<b>X'd</b> Direct axis transient reactance saturated	9,8	11,2	12,6	12,4	11,9	11,4	9,9
<b>T'd</b> Short-Circuit transient time constant	50	50	50	50	50	50	50
<b>X''d</b> Direct axis subtransient reactance saturated	4,9	5,6	6,3	6,2	5,9	5,7	5
<b>T''d</b> Subtransient time constant	5	5	5	5	5	5	5
<b>X''q</b> Quadra. axis subtransient reactance saturated	6,1	7	7,9	7,7	7,4	7,1	6,3
<b>Xo</b> Zero sequence reactance unsaturated	0,5	0,8	0,1	0,7	0,5	0,8	0,1
<b>X2</b> Negative sequence reactance saturated	5,6	6,3	7,1	7	6,7	6,4	5,7
<b>Ta</b> Armature time constant	8	8	8	8	8	8	8

## Others data - Class H / 400 V

	S1	S15	S25	S35	M45	L65	L8
<b>io (A)</b> No load excitation current (SHUNT / AREP or PMG)	0,5/1	0,5/1	0,5/1	0,5/1	0,4/0,8	0,4/0,8	0,4/0,8
<b>ic (A)</b> Full load excitation current (SHUNT / AREP or PMG)	1,3/2,6	1,5/3	1,6/3,2	1,8/3,6	1,6/3,2	1,6/3,2	1,6/3,2
<b>uc (V)</b> Full load excitation voltage (SHUNT / AREP or PMG)	24/12	27/13	30/15	32/16	30/15	29/15	29/14
<b>ms</b> Recovery time ( $\Delta U = 20\%$ trans.)	500	500	500	500	500	500	500
<b>kVA</b> Motor start. ( $\Delta U = 20\%$ sust.) or ( $\Delta U = 50\%$ trans.) SHUNT	120	120	120	128	156	184	213
<b>kVA</b> Motor start. ( $\Delta U = 20\%$ sust.) or ( $\Delta U = 50\%$ trans.) AREP	135	135	135	150	176	200	240
<b>%</b> Transient dip (rated step load) SHUNT / PF : 0,8 LAG	13,6	14,9	16,1	15,8	15,5	15	13,9
<b>%</b> Transient dip (rated step load) AREP / PF : 0,8 LAG	11,4	12,3	13,3	13,1	12,8	12,5	11,6
<b>W</b> No load losses	980	980	980	1110	1120	1210	1410
<b>W</b> Heat rejection	3410	4120	4920	5770	5890	6370	6640

## Transient voltage variation 400 V - 50 Hz

Load application (Shunt excitation)

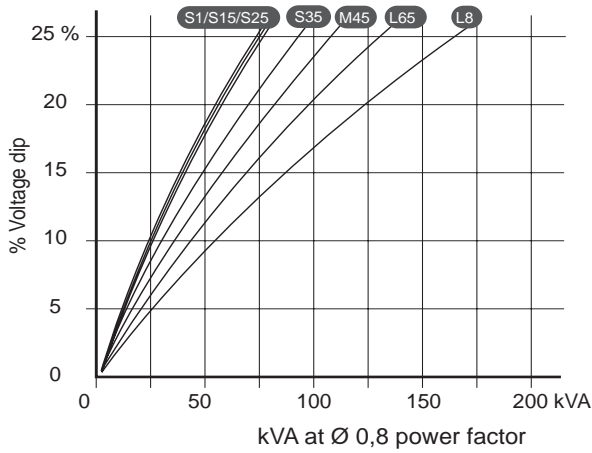

Load application (AREP ou PMG excitation)

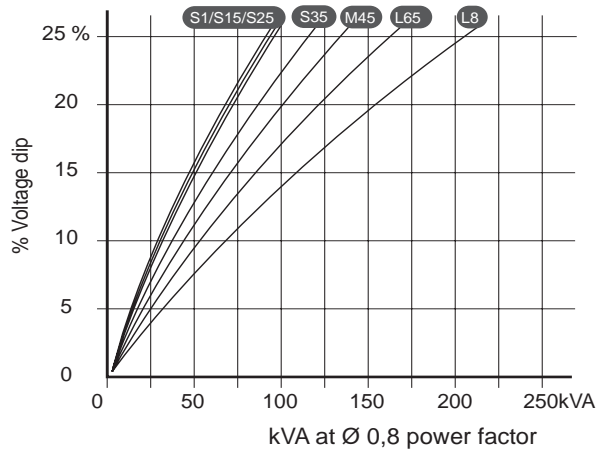

Load rejection (Shunt excitation)

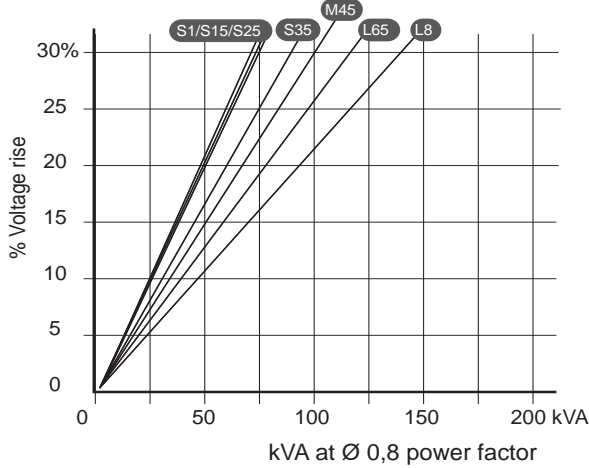

Load rejection (AREP or PMG excitation)

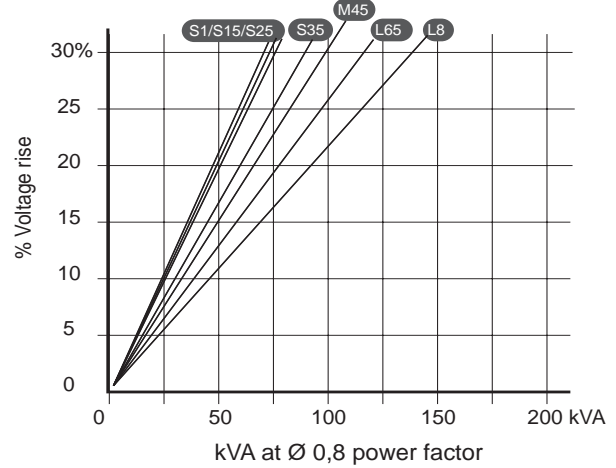

Motor starting (SHUNT excitation)

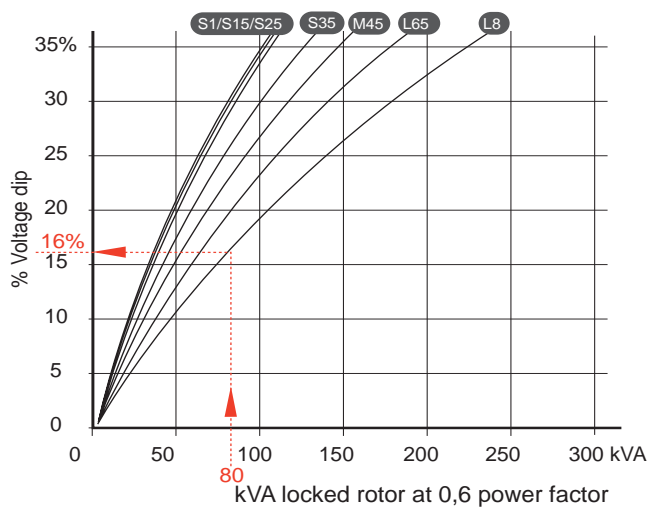

Motor starting (AREP or PMG excitation)

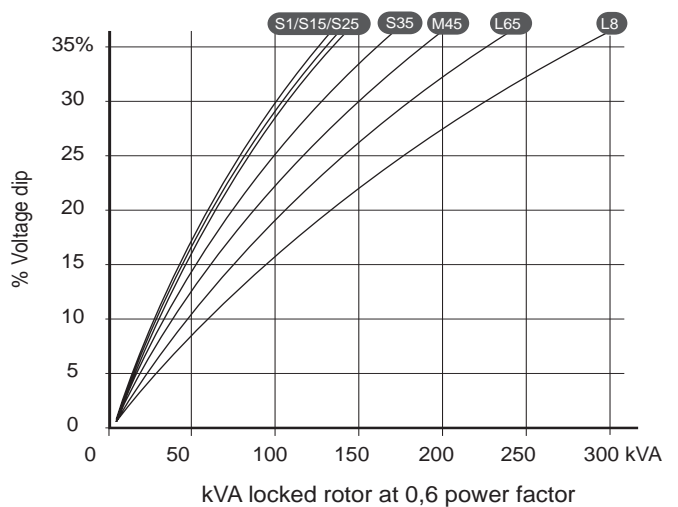

- 1) For a starting P.F. other than 0,6 , the starting kVA must be multiplied by  $K = \text{Sine } \varnothing / 0,8$   
 Calculation example for a different P.F. : Starter motor kVA calculated at 0.4 P.F. = 70 kVA  
 $\blacktriangleright \text{Sin } \varnothing 0,4 = 0,9165 \blacktriangleright K = 1,145 \blacktriangleright \text{kVA corrected} = 80 \text{ kVA} \blacktriangleright \text{Voltage dip corresponding to L8} = 16 \%$
- 2) For voltages other than 400V (Y) , 230V ( $\Delta$ ) at 50 Hz, then kVA must be multiplied by  $(400/U)^2$  or  $(230/U)^2$ .

## Efficiencies 60 Hz - P.F. : 1 / P.F. : 0,8

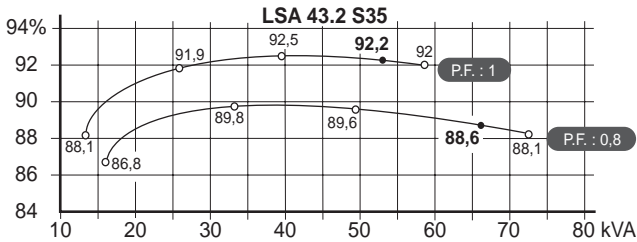
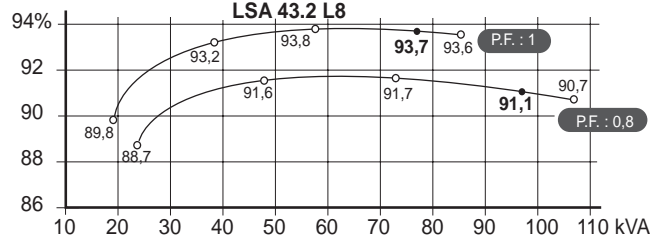
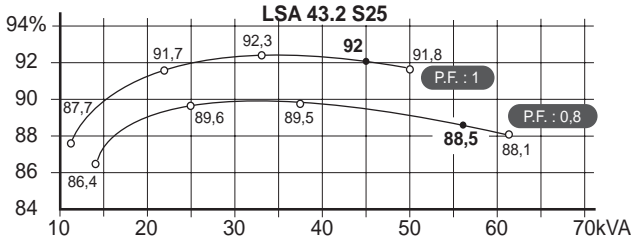
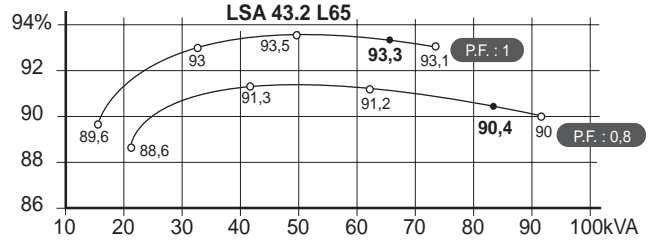
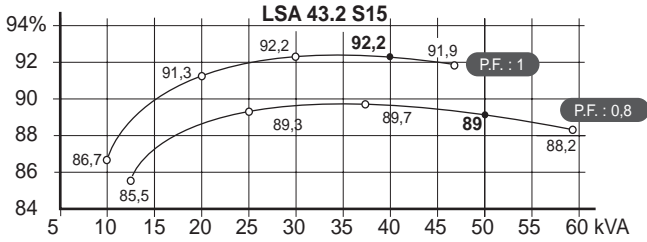
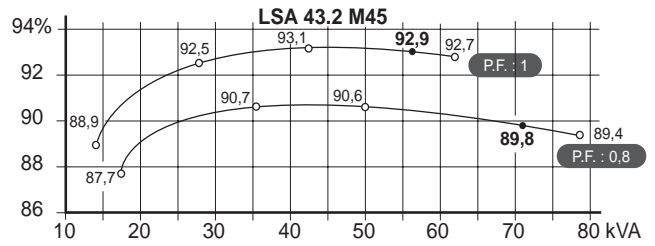
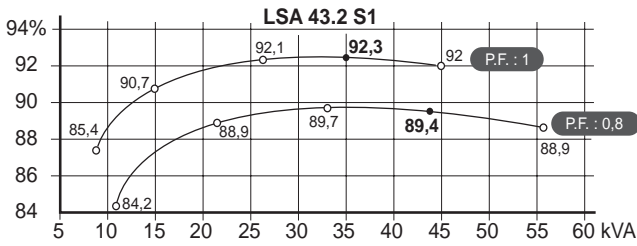

## Reactances (%) . Time constants (ms) - Class H / 480 V

	S1	S15	S25	S35	M45	L65	L8
<b>Kcc</b> Short-circuit ratio	0,52	0,46	0,41	0,42	0,39	0,38	0,4
<b>Xd</b> Direct axis synchro.reactance unsaturated	234	265	297	303	300	306	293
<b>Xq</b> Quadra. axis synchr.reactance unsaturated	140	159	178	181	180	184	176
<b>T'do</b> Open circuit time constant	1131	1131	1131	1177	1270	1354	1431
<b>X'd</b> Direct axis transient reactance saturated	10,3	11,7	13,1	12,8	11,8	11,3	10,2
<b>T'd</b> Short circuit transient time constant	50	50	50	50	50	50	50
<b>X''d</b> Direct axis subtransient reactance saturated	5,1	5,8	6,5	6,4	5,9	5,6	5,1
<b>T''d</b> Subtransient time constant	5	5	5	5	5	5	5
<b>X''q</b> Quadra. axis subtransient reactance saturated	6,4	7,3	8,2	8	7,3	7	6,3
<b>Xo</b> Zero sequence reactance unsaturated	0,4	0,7	0,8	0,4	0,1	0,5	0,8
<b>X2</b> Negative sequence reactance saturated	5,8	6,6	7,4	7,2	6,6	6,3	5,8
<b>Ta</b> Armature time constant	8	8	8	8	8	8	8

## Others data - Class H / 480 V

	S1	S15	S25	S35	M45	L65	L8
<b>io (A)</b> No load excitation current (SHUNT / AREP or PMG)	0,5/1	0,5/1	0,5/1	0,5/1	0,4/0,8	0,4/0,8	0,4/0,8
<b>ic (A)</b> Full load excitation current (SHUNT / AREP or PMG)	1,4/2,8	1,5/3	1,6/3,2	1,8/3,6	1,6/3,2	1,6/3,2	1,6/3,2
<b>uc (V)</b> Full load excitation voltage (SHUNT / AREP or PMG)	25/12	27/14	30/15	33/16	29/14	29/14	29/14
<b>ms</b> Recovery time ( $\Delta U = 20\%$ trans.)	500	500	500	500	500	500	500
<b>kVA</b> Motor start. ( $\Delta U = 20\%$ sust.) or ( $\Delta U = 50\%$ trans.) SHUNT.	151	151	151	162	198	233	269
<b>kVA</b> Motor start. ( $\Delta U = 20\%$ sust.) or ( $\Delta U = 50\%$ trans.) AREP	175	175	175	190	225	265	310
<b>%</b> Transient dip (rated step load) SHUNT / PF : 0,8 LAG	14	15,3	16,5	16,2	15,3	14,9	14
<b>%</b> Transient dip (rated step load) AREP / PF : 0,8 LAG	11,7	12,7	13,6	13,4	12,7	12,4	11,6
<b>W</b> No load losses	1440	1440	1440	1630	1640	1770	2060
<b>W</b> Heat rejection	4150	4910	5760	6730	6420	6970	7570

## Transient voltage variation - 480 V - 60 Hz

Load application (SHUNT excitation)

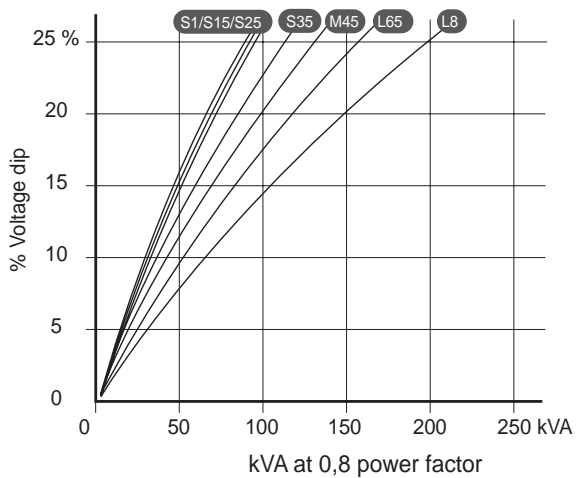

Load application (AREP or PMG excitation)

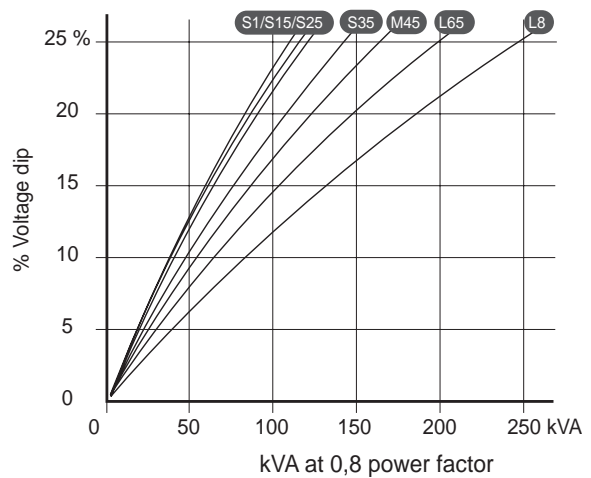

Load rejection (SHUNT excitation)

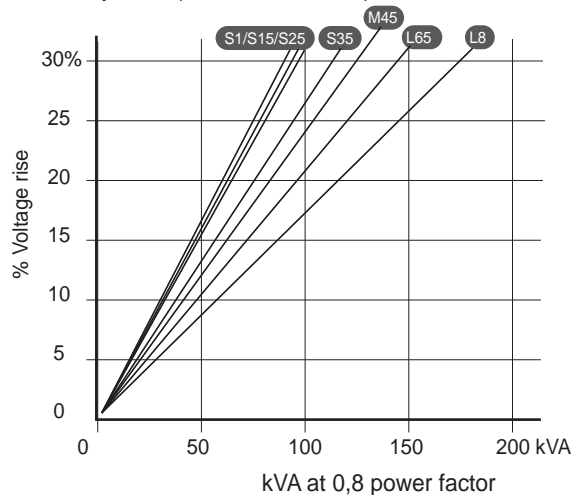

Load rejection (AREP or PMG excitation)

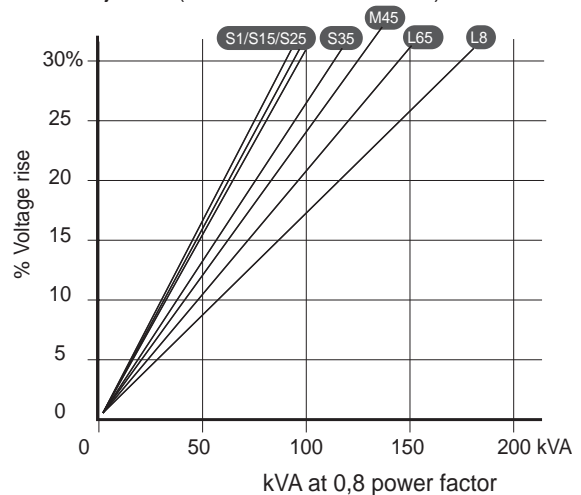

Motor starting (SHUNT excitation)

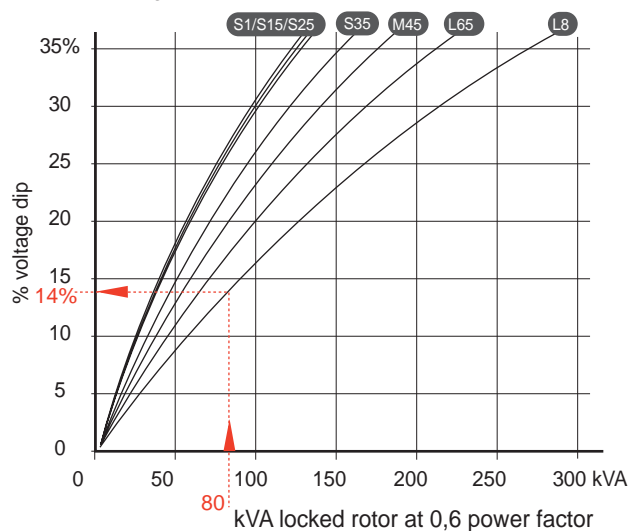

Motor starting (AREP or PMG excitation)

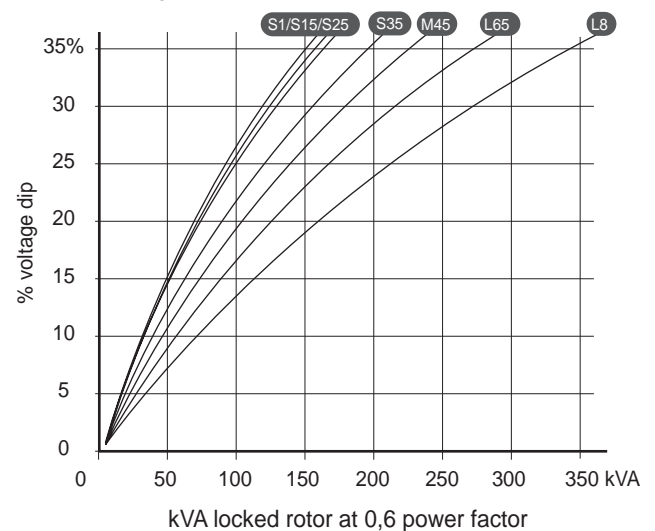

- For a starting P.F. other than 0,6 , the starting kVA must be multiplied by  $K = \text{Sine } \varnothing / 0,8$   
*Calculation example* for a different P.F. : Starter motor kVA calculated at 0.4 P.F. = 70 kVA  
 $\blacktriangleright \text{Sin } \varnothing 0,4 = 0,9165 \blacktriangleright K = 1,145 \blacktriangleright \text{kVA corrected} = 80 \text{ kVA} \blacktriangleright \text{Voltage dip corresponding to L8} = 14 \%$
- For voltages other than 480V (Y), 277V ( $\Delta$ ), 240V (YY) at 60 Hz , then kVA must be multiplied by  $(480/U)^2$  or  $(277/U)^2$  or  $(240/U)^2$  .

**3 phase short-circuit curves at no load and rated speed (star connection Y)**

**LSA 43.2 S1**

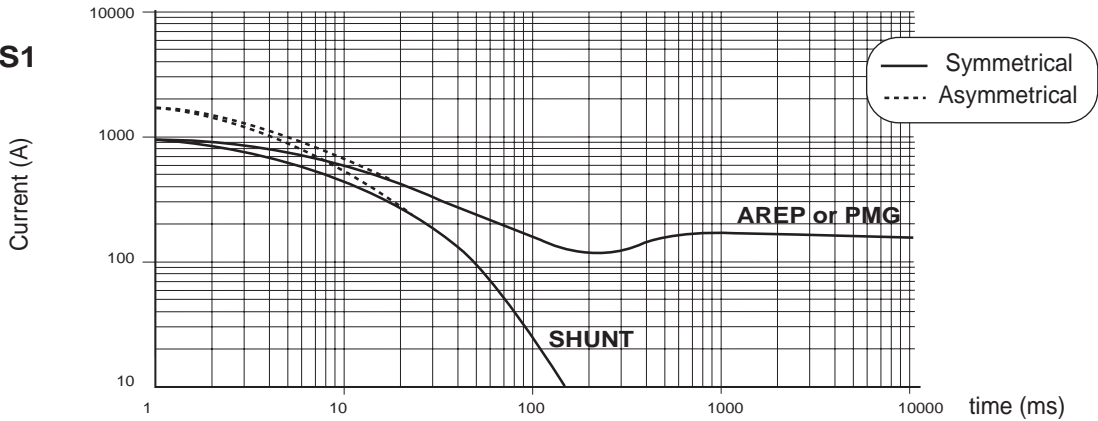

**LSA 43.2 S15**

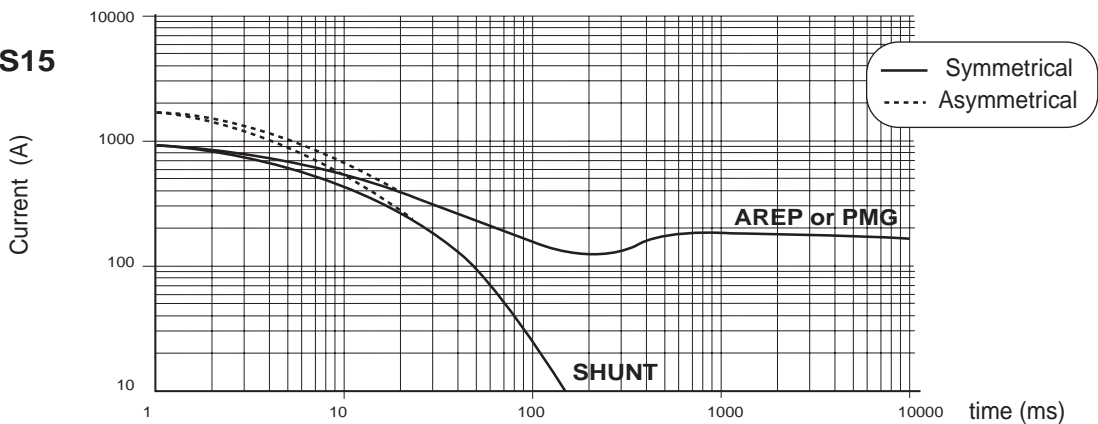

**LSA 43.2 S25**

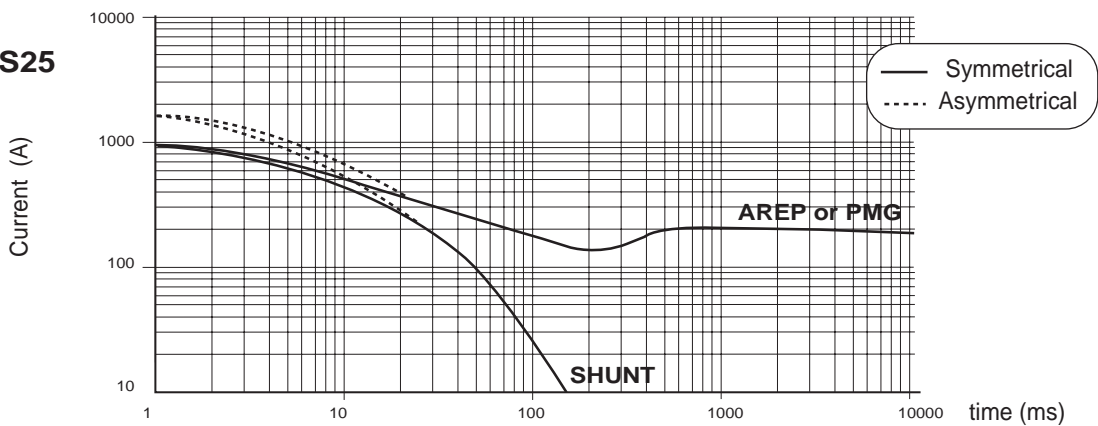

**LSA 43.2 S35**

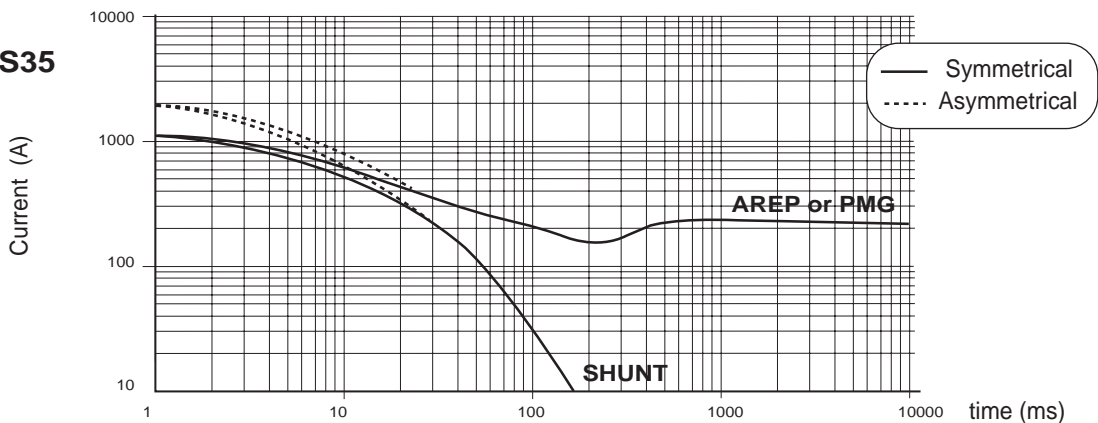



**3 phase short-circuit curves at no load and rated speed (star connection Y)**

**LSA 43.2 M45**

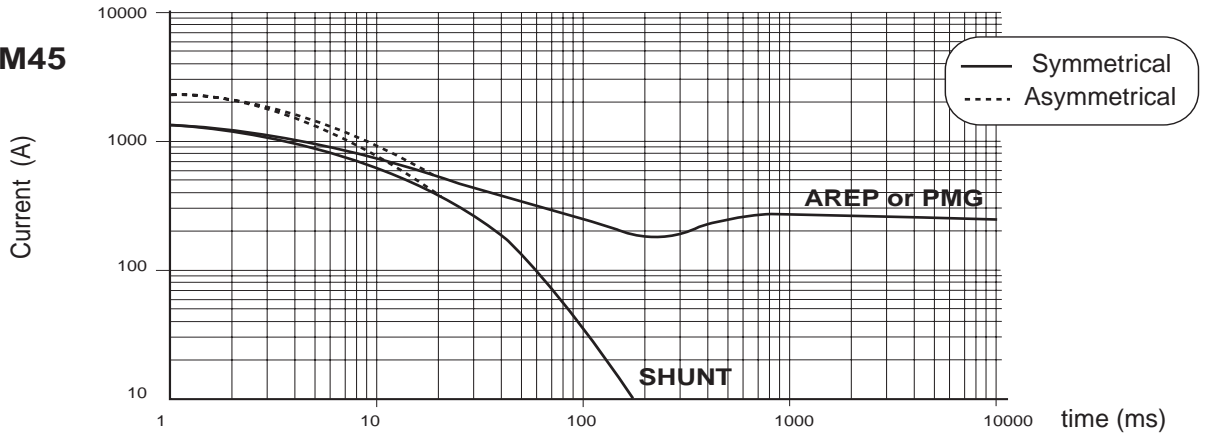

**LSA 43.2 L65**

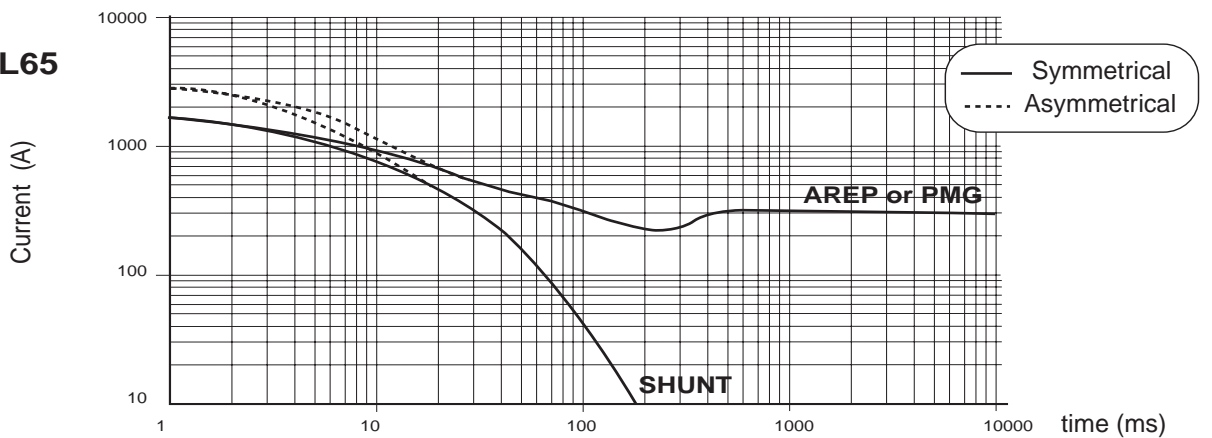

**LSA 43.2 L8**

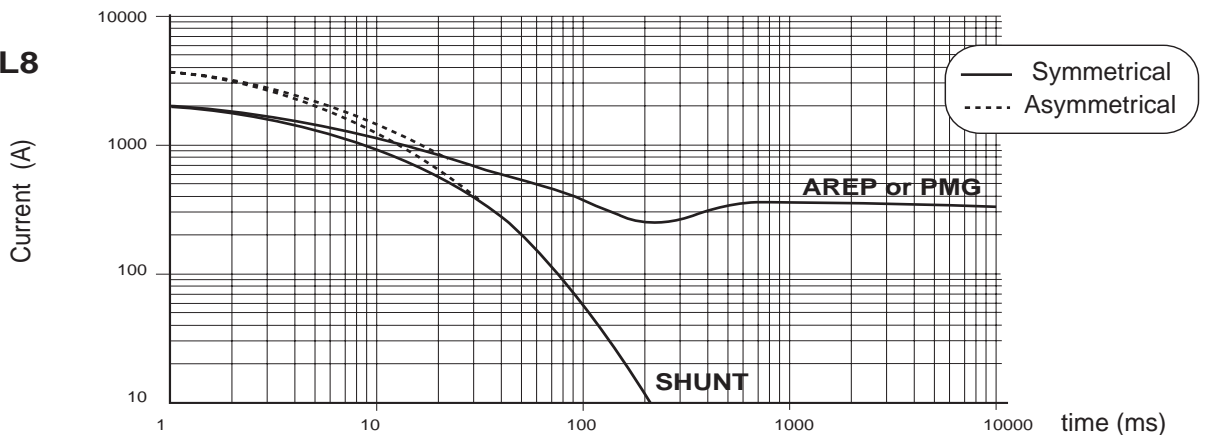

**Influence due to connexion.**

Curves shown are for star (Y) connection.

For other connections, use the following multiplication factors :

- Series delta : Current value x 1,732
- Parallel star : Current value x 2

**Influence due to short-circuit.**

Curves are based on a three-phase short-circuit.

For other types of short-circuit, use the following multiplication factors :

	<b>3 phase</b>	<b>2 phase L - L.</b>	<b>1 phase L - N.</b>
<b>Instantaneous (Max)</b>	1	0,87	1,3
<b>Sustained</b>	1	1,5	2,2
<b>Max sustained duration (AREP/PMG)</b>	10 sec.	5 sec.	2 sec.

## Single bearing dimensions

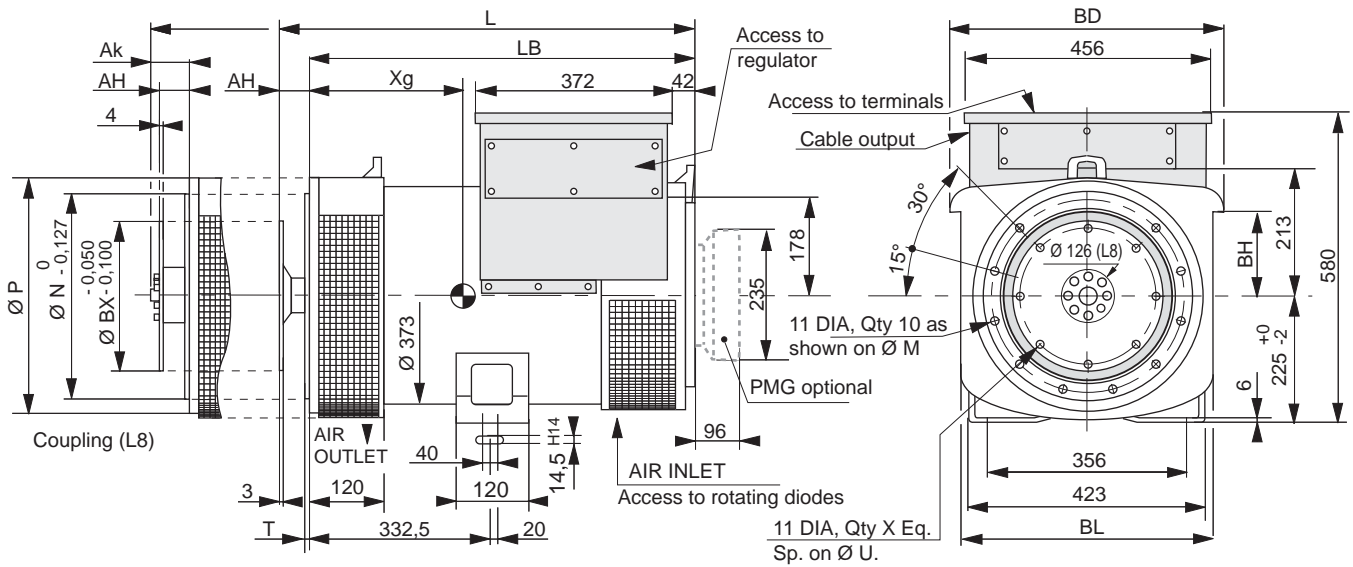

Frame dimensions				
TYPE	L max without PMG	LB	Xg	Weight (kg)
LSA 43.2 S1	627	565	270	210
LSA 43.2 S15	627	565	270	210
LSA 43.2 S25	627	565	270	210
LSA 43.2 S35	627	565	278	230
LSA 43.2 M45	662	600	295	260
LSA 43.2 L65	747	685	315	280
LSA 43.2 L8	754	685	340	320

Coupling			
Flex plate	8	10	11 <sup>1/2</sup>
Flange S.A.E 4	X	X	
Flange S.A.E 3	X	X	X
Flange S.A.E 2		X	X

Flange (mm)							
S.A.E.	BD	BL	BH	P	N	M	T
4	474	452	146	413	361,95	381	5
3	474	452	165	450	409,575	428,625	6
2	514	492	165	490	447,675	466,725	6

Flex plate (mm)					
S.A.E.	BX	U	X	AH	Ak
11 1/2	352,42	333,38	8	39,6	69
10	314,32	295,28	8	53,8	73.2
8	263,52	244,48	6	62	81.4

## Torsional analysis data

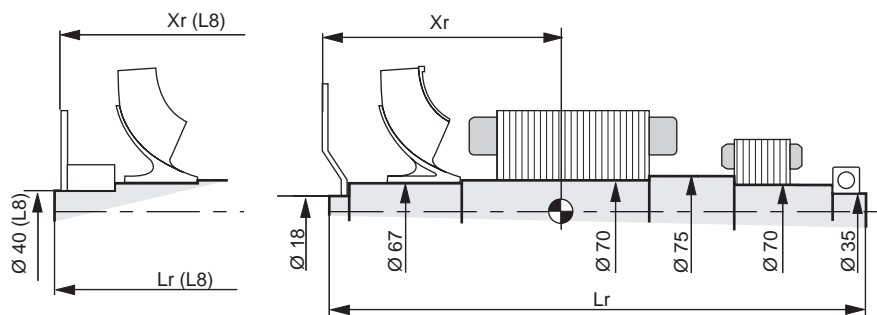

Gravity center : Xr (mm), Rotor length Lr (mm), Weight : M (kg), Moment of inertia : J (kgm <sup>2</sup> ) : (4J = MD <sup>2</sup> )												
TYPE	Flex plate S.A.E. 8				Flex plate S.A.E. 10				Flex plate S.A.E. 11 1/2			
	Xr	Lr	M	J	Xr	Lr	M	J	Xr	Lr	M	J
LSA 43.2 S1	338	590	74,5	0,3446	328	590	75	0,3524	312	590	75,5	0,3634
LSA 43.2 S15	338	590	74,5	0,3446	328	590	75	0,3524	312	590	75,5	0,3634
LSA 43.2 S25	338	590	74,5	0,3446	328	590	75	0,3524	312	590	75,5	0,3634
LSA 43.2 S35	341	590	78,1	0,3653	331	590	78,6	0,3731	315	590	79,1	0,3841
LSA 43.2 M45	358	625	87,7	0,4141	348	625	88,2	0,4219	332	625	88,7	0,4329
LSA 43.2 L65	386	710	100,3	0,4711	376	710	100,8	0,4789	360	710	101,3	0,4899
LSA 43.2 L8	400	742	118,1	0,5546	392	742	118	0,5666	367	742	117,8	0,5826

## Two bearing dimensions

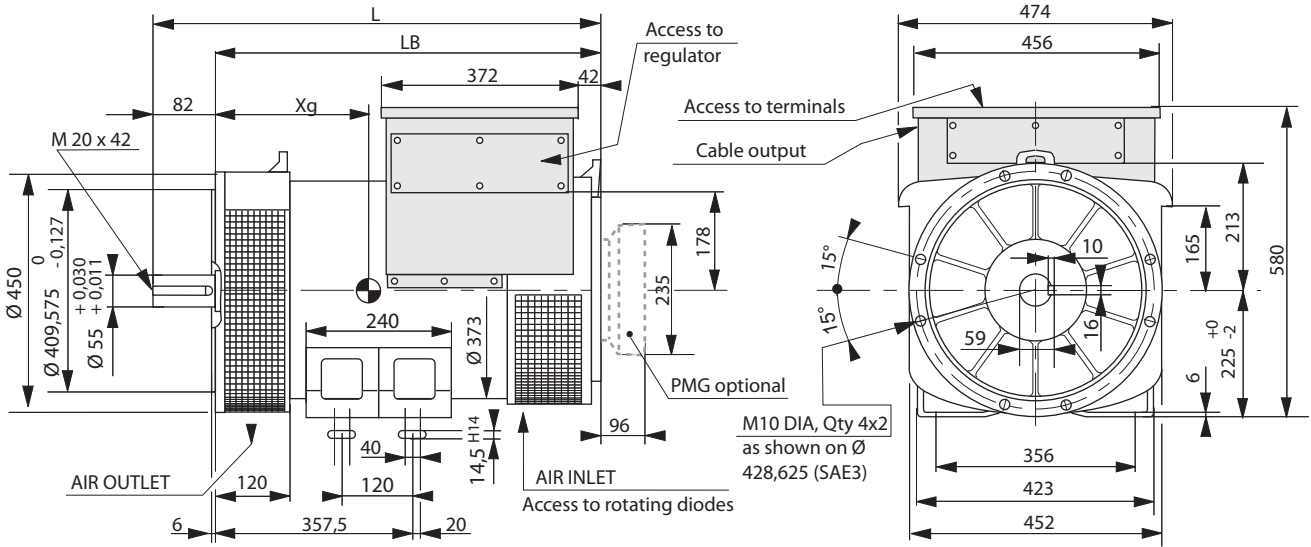

### Frame dimensions

TYPE	L max without PMG	LB	Xg	Weight (kg)
LSA 43.2 S1	672	590	295	220
LSA 43.2 S15	672	590	295	220
LSA 43.2 S25	672	590	295	220
LSA 43.2 S35	672	590	303	240
LSA 43.2 M45	707	625	320	270
LSA 43.2 L65	792	710	340	290
LSA 43.2 L8	792	710	365	330

## Torsional analysis data

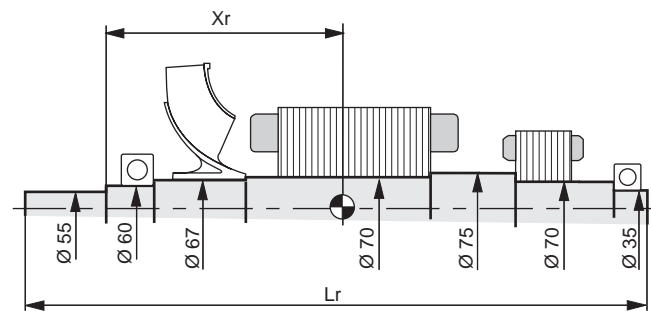

### Gravity center : Xr (mm), Rotor length Lr (mm), Weight : M (kg), Moment of inertia : J (kgm<sup>2</sup>) : (4J = MD<sup>2</sup>)

TYPE	Xr	Lr	M	J
LSA 43.2 S1	301	661	74,2	0,3367
LSA 43.2 S15	301	661	74,2	0,3367
LSA 43.2 S25	301	661	74,2	0,3367
LSA 43.2 S35	305	661	77,8	0,3573
LSA 43.2 M45	321	696	87,5	0,4062
LSA 43.2 L65	349	781	100,1	0,4632
LSA 43.2 L8	362	781	110,9	0,525



**MOTEURS LEROY-SOMER 16015 ANGOULÊME CEDEX - FRANCE**

338 567 258 RCS ANGOULÊME  
S.A. au capital de 62 779 000 ₣

*[www.leroy-somer.com](http://www.leroy-somer.com)*